

THIS COPY IS PROVIDED ON A RESTRICTED BASIS AND IS NOT TO BE USED IN ANY WAY DETRIMENTAL TO THE INTERESTS OF PANDUIT CORP.

PANDUIT PART NO.	WIRE RANGE	MATERIAL	STYLE	"B"	"C"	COLOR (PRINT ON AREA)	LABELS PER ROLL
N050X075CBC	12-10 AWG	GMC4 (VINYL CLOTH)	1	0.50 [12.70]	0.75 [19.05]	WHITE	125
N050X150CBC	8-2 AWG		1		1.50 [38.10]		75
N100X075CBC	12-10 AWG		2	1.00 [25.40]	0.75 [19.05]		125
N100X125CBC	10-6 AWG		1		1.25 [31.75]		75
N100X150CBC	8-2 AWG		2		1.50 [38.10]		
N100X175CBC	6-1 AWG		1		1.75 [44.45]		50
N050X075C1C	12-10 AWG	GMC6 (NYLON CLOTH)	3	0.50 [12.70]	0.75 [19.05]	WHITE	125
N050X075C2C						YELLOW	
N050X125C1C	10-6 AWG				1.25 [31.75]	WHITE	75
N050X125C2C						YELLOW	
N100X075C1C	12-10 AWG			1.00 [25.40]	0.75 [19.05]	WHITE	125
N100X075C2C						YELLOW	
N100X125C1C	10-6 AWG				1.25 [31.75]	WHITE	75
N100X125C2C						YELLOW	

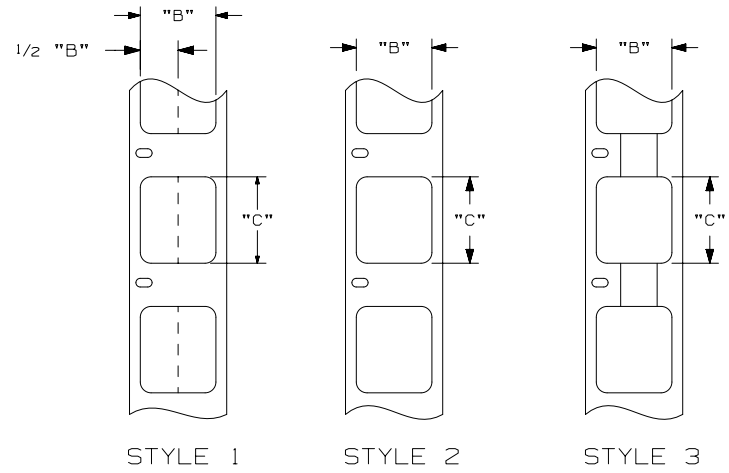
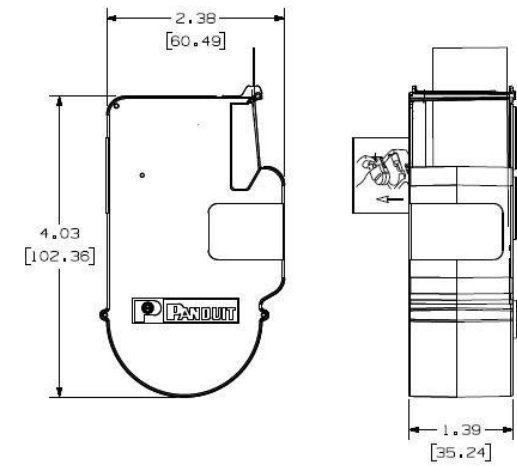

5
5
5
5

5 5

NOTES:
1. DIMENSIONS IN [] ARE IN MILLIMETERS.

REV	DATE	BY	CHK	APR	DESCRIPTION	ECN	TITLE	ITEM REVISION NAME	DATASET FILE NAME	MATERIAL:	DRAWING NUMBER:	
5	9/30/15	RVU	SEWH	JHAC	CHANGE STYLE 2 TO 3 FOR ALL N***X***C1C ONLY. ADD (VINYL CLOTH) TO GMC4, & (NYLON CLOTH) TO GMC6.	GAECN03189	P1 LABEL CASSETTE NON-LAMINATED LABEL CUSTOMER DRAWING 	100743CJ/17	100743CJ_DC_C10693/17E	SEE TABLE	C10693	
4	9/10/14	RVU	SEWH	MSAD	ADD NEW STYLE 3 WITH BRIDGES. CHANGE PN, N050X075C2C, N050X125C2C, N100X075C2C, N100X125C2C FROM STYLE 2 TO 3.	GAECN02298						
3	4/30/14	RVU	SEWH	MSAD	PART NUMBER, ALL N***X***CBC, C*C FOR THE VINYL & NYLON CLOTH CASSETTES SHOW A WIRE RANGE, ALL ARE NOT CORRECT.	GAECN01935						
2	11/17/12	HONG			CHANGE TO CURRENT TEMPLATE AND ADDED N100X075CBC	GAECN00399						
1	06/25/10	RVU			ADD NEW PN N***X***C*C.	6029						
0	04/21/08	RVU			DRAWING RELEASE	5403						
REV	DATE	BY	CHK	APR	DESCRIPTION	ECN	DRAWN BY RVU	DATE 4/22/08	CHK MSAD	SCALE NTS	SHT 1 OF 1	SIZE A

D101000DA/12