

REVISIONS		DATE	DWN	APVD
AENDERUNGEN	DESCRIPTION			
P	LTR			
	A	27.02.96	L.Post	-
	A1	24-APR-98	KBWWE	-

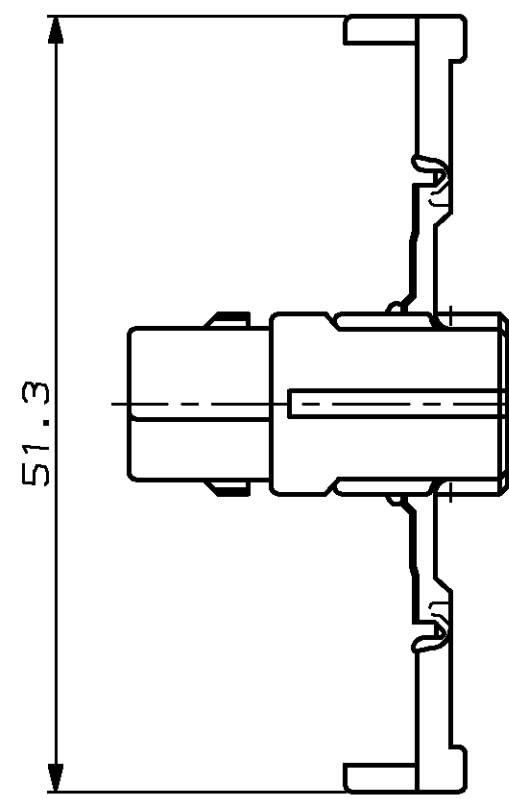

Bemerkungen

- △ 1 AMP-Logo
AMP-LOGO
- △ 2 Bestell-Nummer
ORDER-NO.
- △ 3 Werkzeugänderungsindex
REVISION STATUS OF THE MOULD
- △ 4 Werkstoffkennzeichnung
MATERIAL MARKING
- △ 5 Produktionsdatum
PRODUCTION DATE
- △ 6 Feld für Nestmarkierung
FIELD FOR CAVITY MARKING
- △ 7 Strichzahl ist abhängig von der Verarbeitungsmaschine
PART NUMBER WILL BE DICTATED BY PROCESS

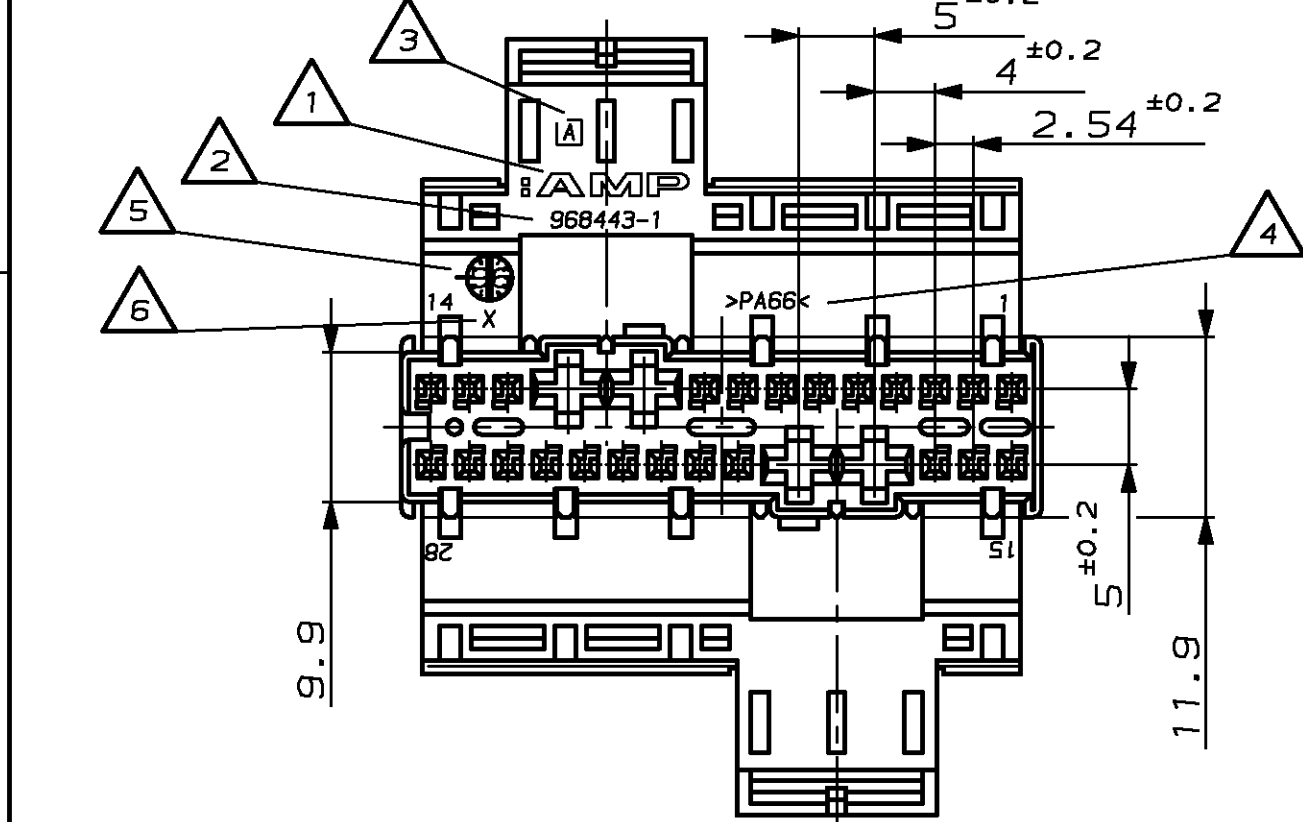
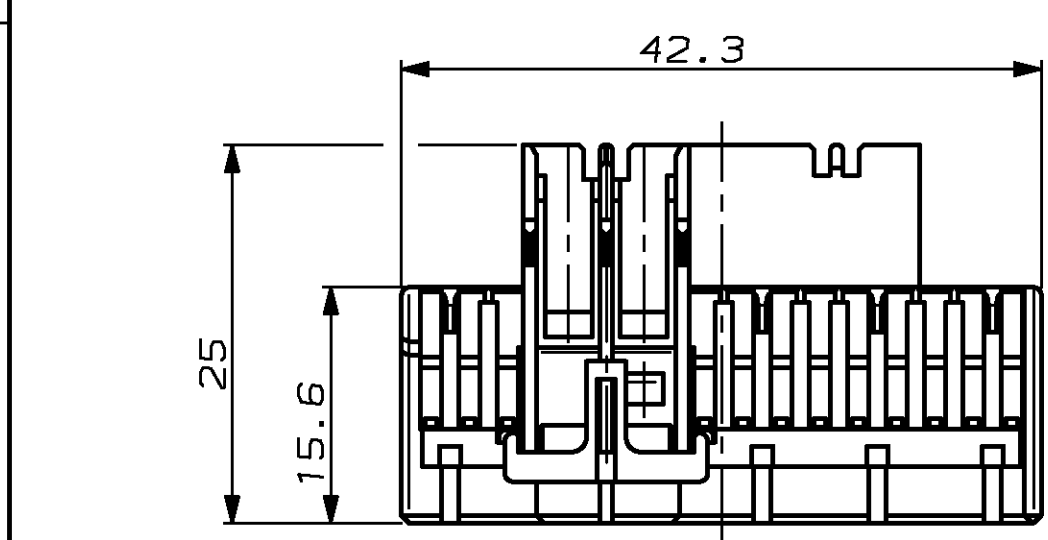

JUNIOR-POWER-TIMER	927 768-1	927 777-1	1.5 - 2.5 mm ²	CuFe2	PRE TIN PLATED	878 180-2	169 400 MATRIZE, 734 468
JUNIOR-POWER-TIMER	927 771-1	927 779-1	0.5 - 1 mm ²	CuFe2	PRE TIN PLATED	878 181-2	169 400 MATRIZE, 169 917
MODU IV	963 720-1	965 969-1	0.2 - 0.50mm ²	CuSn	PRE TIN PLATED	878 635-7	-
MODU IV	167 418-1	167 419-1	0.2 - 0.56mm ²	CuSn	PRE TIN PLATED	872 006-7	169 481-1

CONTACTS	AMP ORDER NUMBER		WIRE RANGE	MATERIAL	FINISH	CRIMP TOOL	
	STRIP FORM	LOOSE PIECE				APPLICATOR	HAND TOOL
	-	968443-1	A	-	PA66	schwarz	JPT/MODU IV Gehäuse, 28pol.

<p>THIS DRAWING IS A CONTROLLED DOCUMENT FOR AMP INCORPORATED. IT IS SUBJECT TO CHANGE AND THE CONTROLLING ENGINEERING ORGANIZATION SHOULD BE CONTACTED FOR THE LATEST REVISION. DIESER ZEICHNUNGS-DOKUMENT WIRD DURCH AMP INCORPORATED KONTROLLIERT. ÄNDERUNGEN, DIE DEN TECHNISCHEN FORTSCHRITT DIENTEN, SIND VORBEHALTEN. DEN JEMALS LETZTUEBLICHEN ÄNDERUNGSSTAND ERFAHREN SIE AUF ANFRAGE.</p>		<p>DWN L.Post 27-FEB-96 CHK J.Kunze 28-FEB-96</p>		<p>AMP AMP Deutschland GmbH D - 63225 Langen</p>	
<p>DIMENSIONS, DIMENSIONEN, mm</p>		<p>TOLERANCES UNLESS OTHERWISE SPECIFIED, ALL GENERAL TOLERANCES</p>		<p>NAME JPT/MODU IV-HOUSING, 28POS. JPT/MODU IV-Gehäuse, 28pol.</p>	
<p>0 PLC ±0.05 mm 1 PLC ±0.05 mm 2 PLC ±0.05 mm 3 PLC ±</p>		<p>n. ISO 2768 - mH - E n. DIN 16901 - 140</p>		<p>PRODUCT SPEC PRODUKTSPEZ.</p>	
<p>ANGLES /WINKEL ±</p>		<p>FINISH/OBERFLÄCHE/FARBE</p>		<p>APPLICATION SPEC VERARBEITUNGSSPEZ.</p>	
<p>MATERIAL</p>		<p>WEIGHT GEWICHT -</p>		<p>SIZE CAGE CODE DRAWING NO ZEICHNUNGS-NR. A3 00779 C-968 443</p>	
<p>CUSTOMER DRAWING /KUNDENZEICHNUNG</p>		<p>MASSSTAB 2:1</p>		<p>RESTRICTED TO NUR FUER</p>	
<p>BLATT 1 OF 1</p>		<p>REV A1</p>		<p>REVISIONS</p>	